

Photovoltaic power generation insulation board factory direct sales

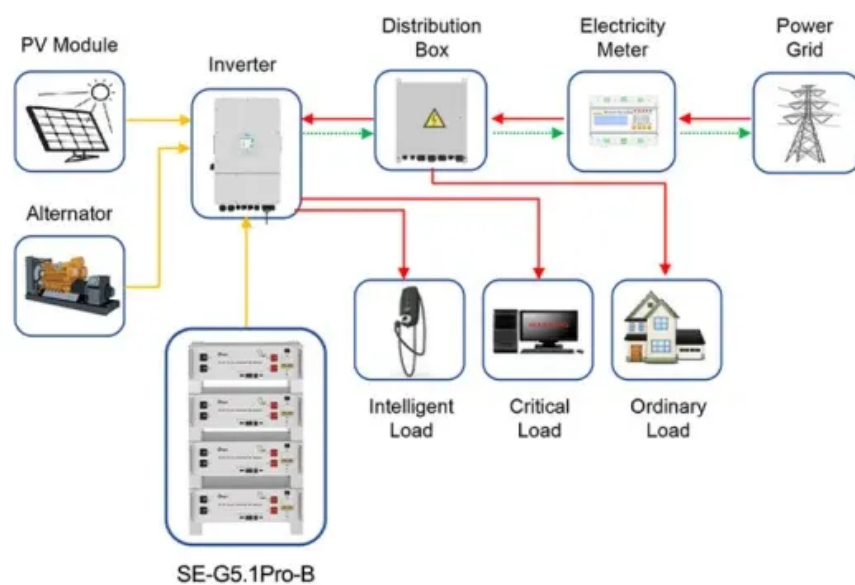

Application scenarios of energy storage battery products



Photovoltaic power generation insulation board factory direct sales



[How Do Solar Cells Work? Photovoltaic Cells Explained](#)

The conversion of sunlight, made up of particles called photons, into electrical energy by a solar cell is called the "photovoltaic effect" - hence why we refer to solar cells as "photovoltaic", or PV

Solar Programs

Local solar projects help LADWP to meet renewable energy targets and reduce the carbon footprint created by fossil fuel-burning power plants. Solar also brings economic benefits for LA as a catalyst



Factory direct insulation board

Factory-direct insulation boards are high-performance thermal solutions designed for residential, commercial, and industrial applications. These boards offer superior energy efficiency,

Commercial Insulation Distributor

General Insulation Company is a distributor and supplier that stocks and fabricates a wide variety of industrial, commercial, and fire-stopping products for construction-related markets.



Photovoltaics

Photovoltaics (PV) is the conversion of light into electricity using semiconducting materials that exhibit the photovoltaic effect, a phenomenon



Photovoltaics and electricity

A photovoltaic (PV) cell, commonly called a solar cell, is a nonmechanical device that converts sunlight directly into electricity. Some PV cells can convert artificial light into electricity. Sunlight is composed

studied in physics, photochemistry, and electrochemistry. The



Photovoltaics , Department of Energy

Photovoltaic (PV) technologies - more commonly known as solar panels - generate power using devices that absorb energy from sunlight and convert it into electrical energy through semiconducting

What Are Photovoltaics? (2026) , ConsumerAffairs(R)

Photovoltaic technology lets you generate electricity from a renewable source: the sun. Unlike traditional methods of electricity generation, which often rely on fossil fuels, photovoltaics



[Factory Direct Sales of New Materials Solar Photovoltaic Panels PV](#)

Guangdong Weishi New Materials Co., Ltd. is a professional manufacturer specializing in the production of composite materials, supplemented by processing, sales, and services.

[Photovoltaic Effect: How Solar Energy Physics Turns Light into](#)

The cornerstone of solar panel technology lies in the photovoltaic effect, a natural physical process that converts light energy directly into electrical energy.



Photovoltaics (PV)

Photovoltaic systems work by utilizing solar cells to convert sunlight into electricity. These solar cells are made up of semiconductor materials, such as silicon, that absorb photons from

Solar Photovoltaic: Everything You Should Know

What is a solar photovoltaic (PV) system? A solar PV system is a technology that converts sunlight directly into electricity using the photovoltaic effect.



[A review of solar photovoltaic technologies: developments, challenges](#)

Solar photovoltaic (PV) technology has emerged as a key renewable energy solution, yet its widespread adoption faces several technical and economic challenges.

Contact Us

For catalog requests, pricing, or partnerships, please visit:
<https://peyronies.us>